

THIS DRAWING IS UNPUBLISHED. RELEASED FOR PUBLICATION
 © COPYRIGHT BY TYCO ELECTRONICS CORPORATION. ALL INTERNATIONAL RIGHTS RESERVED.

LOC	DIST	REVISIONS					
		P	LTR	DESCRIPTION	DATE	DWN	APVD
G	14		M5	REVISED PER ECR-08-022232	06OCT08	HMR	TM

AMP
WIRE RANGE

16-14 AWG
SOLID OR STRANDED

- 1 STAMP AMP 16-14* APPROX AS SHOWN
- 2 MAXIMUM LENGTH DOES NOT INCLUDE MANUFACTURING TABS
- 3 MATERIAL: COPPER PER ASTM B-152 ANNEALED
- 4 FINISH: TIN PLATE 0.00254 [.000100] MIN THK PER ASTM B-545
- 5 FINISH: TIN/LEAD (60/40) PLATE, .000100 MIN THK PER SAE-AMS-P-81728
- 6 GOLD PLATE .000100 MIN PER ASTM B488 OVER NICKEL PLATE .000050 MIN PER QQ-N-290
- 7 UL LISTED E13288, 16-14 AWG SOLID OR STRANDED
- 8 CSA CERTIFIED LR7189, 16-14 AWG SOLID OR STRANDED
- 9 PRELIMINARY - NOT FOR PRODUCTION

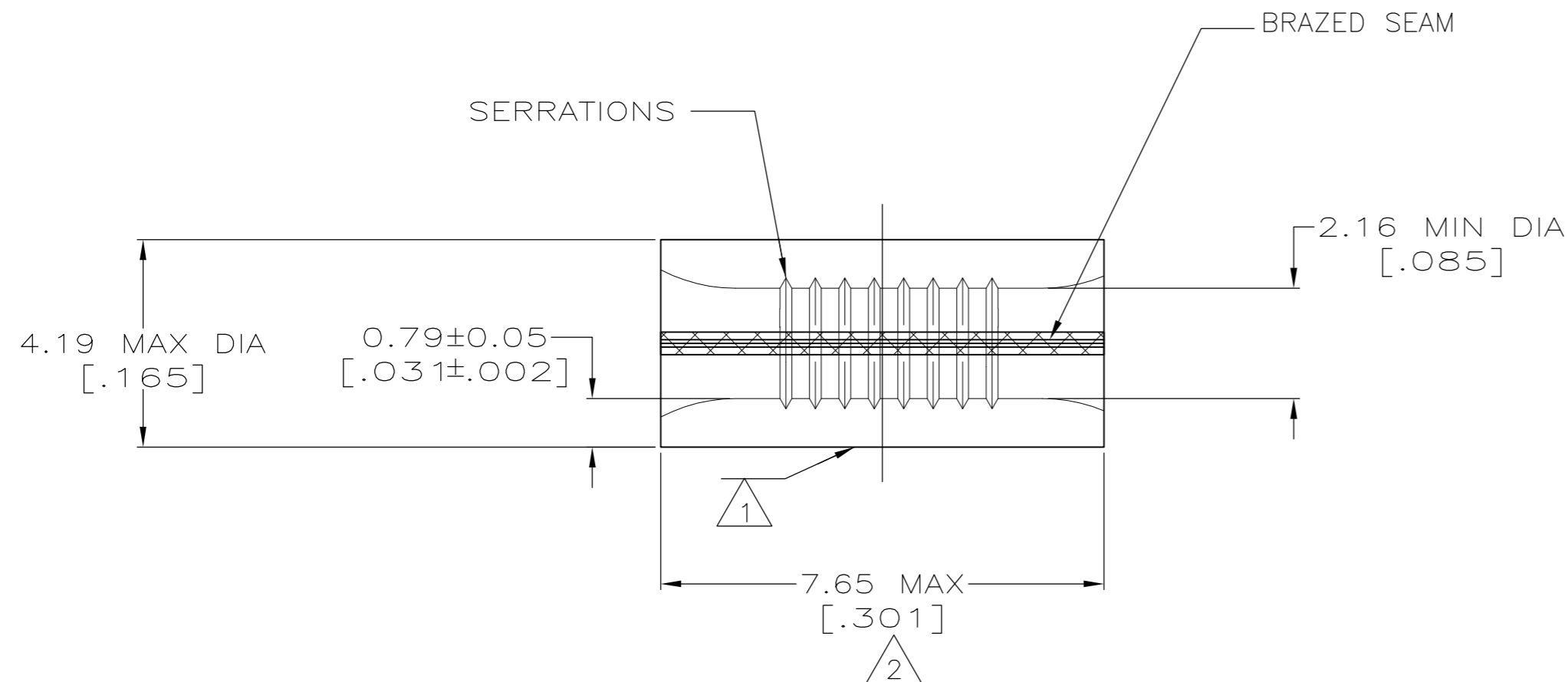

APPROVALS	FINISH	QTY	PACKAGE TYPE	PART NO
7 8	4	10	SEALED BAG	8-34137-5
7 8	4	100	LOOSE PIECE, BOX	8-34137-1
----	5	----	LOOSE PIECE	9 34137-3
----	6	----	LOOSE PIECE	34137-2
7 8	4	----	LOOSE PIECE	34137

AMP INCORPORATED CUSTOMER SERVICE SYSTEMS		MAX RECOMMENDED OPERATING TEMPERATURE: 170° C
FOR ADDITIONAL PRODUCT INFORMATION OR COPIES OF DRAWINGS AND TECHNICAL DOCUMENTS 1-800-522-6752	PRODUCT INFORMATION CENTER	VOLTAGE RATING: N/A
FOR APPLICATION TOOLING INFORMATION 1-800-722-1111	TOOLING ASSISTANCE CENTER	CIRCULAR MIL AREA: 1.04-2.62mm² [2,050-5,180] SOLID OR STRANDED
FOR ORDER ENTRY 1-800-526-5142	THIS DRAWING IS A CONTROLLED DOCUMENT FOR AMP INCORPORATED. IT IS SUBJECT TO CHANGE AND THE CONTROLLING ENGINEERING ORGANIZATION SHOULD BE CONTACTED FOR THE LATEST REVISION.	

THIS DRAWING IS A CONTROLLED DOCUMENT.		DWN TA BRINKMAN 4-13-93	Tyco Electronics Corporation Harrisburg, PA 17105-3608	
DIMENSIONS: INCHES		CHK DA PATTERSON 4-13-93		
TOLERANCES UNLESS OTHERWISE SPECIFIED:		APVD DA PATTERSON 4-13-93	NAME	
0 PLC ± - 1 PLC ± - 2 PLC ± - 3 PLC ± - 4 PLC ± - ANGLES ± -		PRODUCT SPEC	SPLICE, PARALLEL, SOLISTRAND	
MATERIAL - 3		FINISH SEE TABLE	SIZE A2	RESTRICTED TO
		WEIGHT -	CAGE CODE 00779	DRAWING NO C=34137
		CUSTOMER DRAWING	SCALE 10:1	SHEET 1 of 1 REV M5